



Composite Frame Care Kestrel RT Series

RT Models

Congratulations on your Kestrel purchase! The carbon fiber/epoxy composite of your Kestrel frame is significantly lighter and stronger than metals and, barring accident, will stand up to a lifetime of the hardest training and racing. But composite frames require slightly different care than metal ones. Even if you've been working on bikes for years, please take a few minutes to read the following guidelines before starting.

GENERAL

Repair stands. The mechanical action of a repair stand concentrates enormous loads in a small area. As with any fine bicycle, **clamp your Kestrel by the round seat post only to avoid damage to the frame.** If your RT is equipped with an aerodynamic post, you may need to remove this post and insert a round (27.2mm) seat post with the seat post adapter supplied with your frame.

Dropout spacing. Your Kestrel RT series is molded with 130mm dropout spacing to accept 130mm hubs. Do not stretch or compress your frame's dropout spacing more than 2mm. As it is impossible to bend the carbon/epoxy composite of your Kestrel frame, **do not attempt to cold set (bend) the frame or dropouts.**

MAINTENANCE

Seat post. The RT series frame accepts the RT EMS PRO Aerodynamic Seat Post or, using the supplied adapter, a standard 27.2mm diameter seat post. Minimum seat post insertion into the frame is 70mm (2.75 inches). Maximum seat post insertion is 180mm (7 inches); the carbon seat tube sleeve extends only this far into the frame and the seat tube tapers to a smaller diameter beyond that. *Inserting the seat post or reaming out the internal sleeve beyond this depth will damage the composite walls of the frame.* Seat posts may easily be cut down if a lower seat height is desired as long as minimum insertion is maintained. A standard fine tooth hacksaw will work. Be certain to remove any burrs on the post before reinserting into the frame. *Some seat post manufacturers may require a minimum insertion of more than 70mm.* Be sure that the supplied washer is in place under the head of the binder bolt. The seat binder bolt should be torqued to 7 – 9 Nm. To work on the frame in most repair stands, you must use a round 27.2mm post and the seat post adapter supplied with your frame. Note that the seat binder clamp is bonded in place and is *not* removable. It is highly recommended that you use “**Carbon Prep**” when installing your seat post. Most bicycle stores have this in stock. Apply a light coat on the seat post prior to installing it in the frame.



Headset. Your headset cups are bonded in at the factory. Simply install the bearings and the crown race onto the seat of the fork. Be sure to only use the Kestrel compression plug that is specifically designed for carbon fiber steerer tubes.

Bottom bracket. Grease bottom bracket threads and faces before installing bottom bracket cups. Follow the bottom bracket manufacturer's instruction regarding installation torque. *Caution: do not use LocTite or other thread locking compounds on the bottom bracket threads! LocTited cups require additional torque to remove, which may exceed the torque limit on the bottom bracket of your Kestrel frame.*

Front derailleur mounting bracket. Grease the threads of the mounting bolts before installation and make sure they are tight enough to keep the bracket from moving during front derailleur shifts. The bolts should be torqued to 2.5 Nm or 30 in-lbs. The bolts are threaded into aluminum threaded inserts, so be careful not to strip the threads. Some adjustment of the bracket position is possible by loosening the two mounting bolts and shifting the bracket relative to the frame.

Front brake. You must use the long brake nut supplied with the frameset to install your front brake. You also need to use any washers that come with your brake assembly. The brake may not tighten properly without the proper washers. Contact your Kestrel dealer if you do not have the long brake nut.

Cable routing. Your RT frame features fully internal cable routing. The rear brake cable housings terminate at the cable port on the front of the top tube and at the port insert in the seat collar; the cable runs bare inside the top tube. Your frame comes with plastic dummy housing inside the top tube for ease of assembly. Fig. 1: To install the brake cable, thread the cable from the brake housing through the cable port and into the dummy housing. When the cable comes out the end by the seat binder remove the dummy housing and insert the port into the hole in the frame. Carefully thread the port screw with a 2mm hex key into the threaded insert in the frame and insert the housing into the cable port. Fig. 2: At the seat clamp exit hole put the black port insert onto the cable and install the rear brake cable housing.

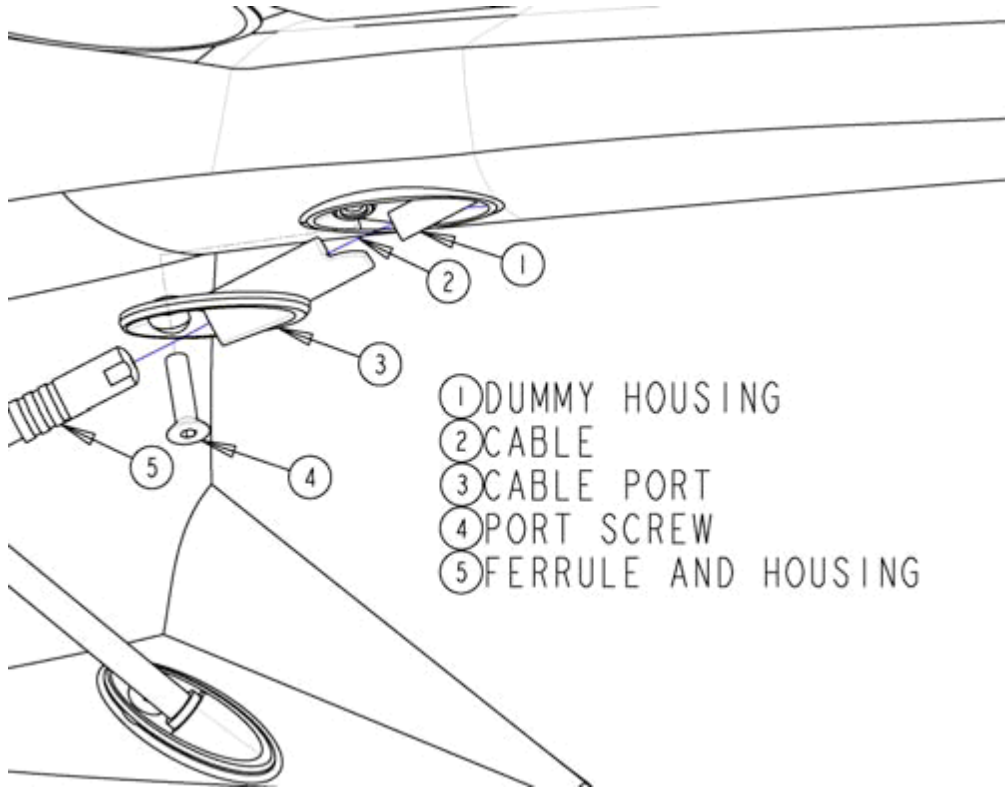

- ① DUMMY HOUSING
- ② CABLE
- ③ CABLE PORT
- ④ PORT SCREW
- ⑤ FERRULE AND HOUSING

Figure #1



- ① SEAT CLAMP
- ② CABLE
- ③ PORT INSERT
- ④ FERRULE AND HOUSING

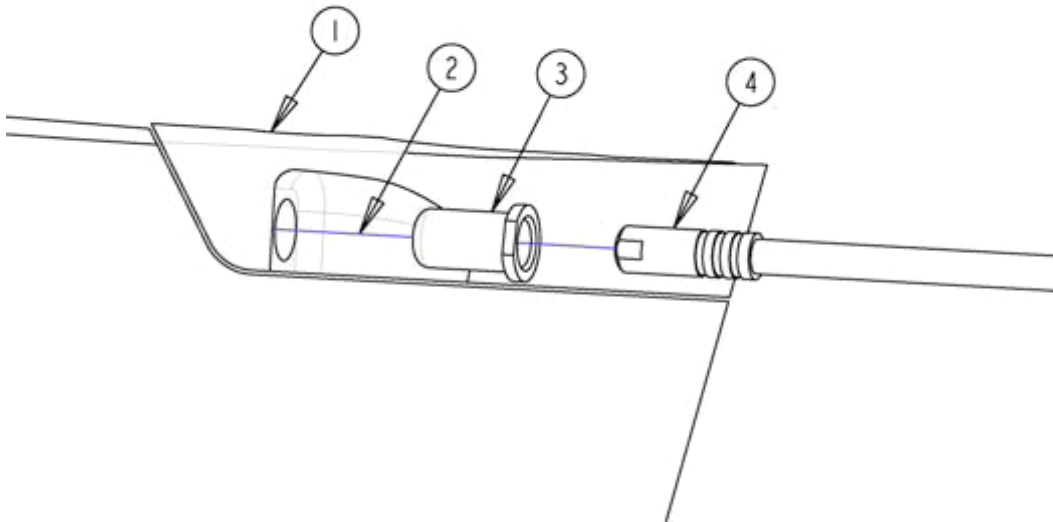

Figure #2

The shift cable housings terminate at cable ports at the front of the down tube and bare shifter cables run through the down tube (fig. 1). Both cables exit at the bottom of the down tube and into the removable plastic cable guides. To install cables, remove the plastic guides from underneath the BB and insert the cable into the appropriate down tube port (removing the port is not necessary). With the bike level the cable should fall out of the scoop in the bottom of the down tube, if not retry. When routing the derailleur cables, *take care not to cross the cables over each other inside the frame*, as poor shifting performance will result. Fig 3: The front derailleur cable is routed through the plastic guide, into the hole behind the BB and out the exit hole in the seat tube heading to the front derailleur. The rear derailleur cable is routed through the plastic guide and into the dummy housing running through the chain stay. When the cable comes out the other end, remove the dummy housing and insert the port into the hole in the frame (Fig 4). Carefully thread the port screw into the threaded insert in the frame. Finally slide the rear cable housing over the cable and push the housing into the cable port.

Note: As with any bike, use ferrules on all cable housing ends, and lubricate all cables where they pass through any housing, ports, or plastic guides.



Derailleur hanger. The RT frames come equipped with a replaceable derailleur hanger. If the hanger is bent or damaged in any other way, it should be removed and replaced. Contact your Kestrel dealer for assistance.

- ① REAR DERAILEUR CABLE
- ② REAR CABLE GUIDE
- ③ FRONT DERAILEUR CABLE
- ④ FRONT CABLE GUIDE

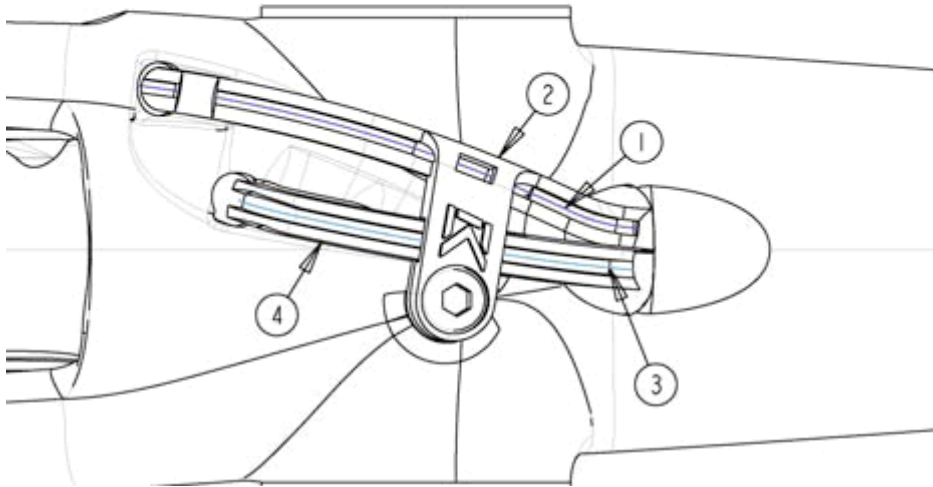

Figure #3



- ① DUMMY HOUSING
- ② CABLE
- ③ CABLE PORT
- ④ PORT SCREW
- ⑤ FERRULE AND HOUSING

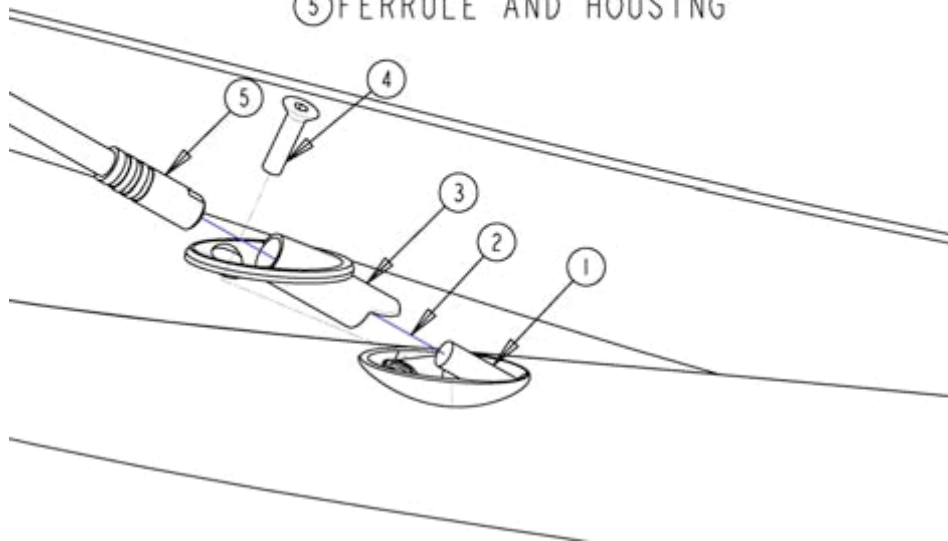

Figure #4

When removing any shift or brake cable from your frame, be sure to first run sections of cable housing or other suitable tubing over the cable and through the frame tubes, then *carefully* remove the cable, leaving the “dummy” housing in place. *Note: if you already removed the disposable housing before reading this section, don't panic! This is how we install the housing at the factory:* Rear brake: remove the cable entry port on the front of the top tube and the port insert from the seat clamp. Put a slight kink about three inches from the end of a brake cable. Feed it into the frame starting at the seat clamp just far enough to reach the cable entry hole in the front of the top tube. Twist the cable until you see it line up with the hole and push it through. Thread dummy housing over the cable and push the housing through the tube and out the hole in the seat clamp. Once the housing is through remove the feeder cable and install your new cable and housing. Chain stay cable: Remove the chain stay exit port and orient the frame so that the chain stay is vertical with the dropouts at the top. Put a slight kink about three inches from the end of a derailleur cable. Insert the cable into the hole at the front of the chain stay just far enough to reach the exit hole. Twist the cable until it lines up with the exit hole and push it through. Thread dummy housing over the cable and push the housing out through the hole in the front of the chain stay. Once the housing is through remove the feeder cable and install your new cable and housing.



Derailleur hanger. The RT comes equipped with a replaceable derailleur hanger. If the hanger is bent or damaged in any way, it should be removed and replaced. Contact your Kestrel dealer for assistance. The derailleur hanger screws (drive-side dropout) may of course be removed or replaced as needed. Be sure to fully tighten the screws when re-attaching.

PAINT

Caution: any paint stripper which will remove epoxy paint will damage the epoxy resin matrix which holds your frame together. Do not use any paint stripper on your Kestrel frame. If you decide to have your Kestrel repainted, we recommend hand sanding to remove the decals and scuff the topcoat. Do not bake over 150 degrees F. Do not sand away any composite material. Do not sandblast, bead blast, plastic media blast, or blast with any other media. Blasting can remove structural composite material and could make your Kestrel unsafe.

Copyright 2010, Kestrel Bicycles 10940 Dutton Road, Philadelphia, PA 19154
(215) 824-3854 P / (215) 824-1051 F kestrelbicycles.com / email: info@kestrelbicycles.com

Rev. 5/15/09